

Cowl front ring laminated from 2 layers of 1/8 sheet. Wrap with 1/32 sheet & add 3/32 sheet rocker box "bumps".

1/32 sheeting typical

NOTE: overall aircraft color is blue-gray

Fuselage frame is 3/32 square or hard 1/16 square

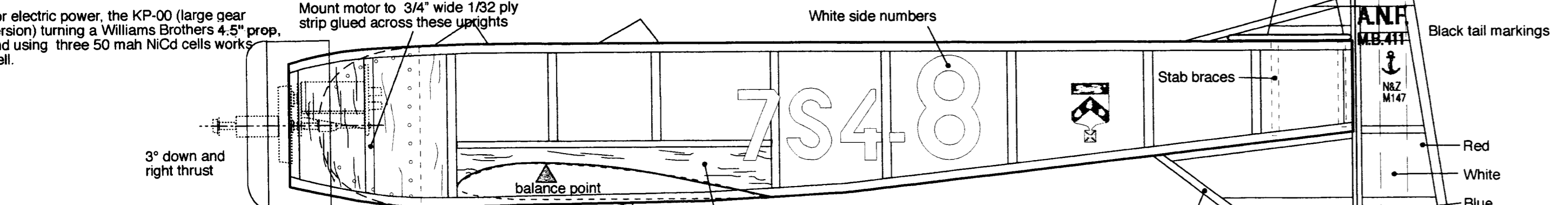
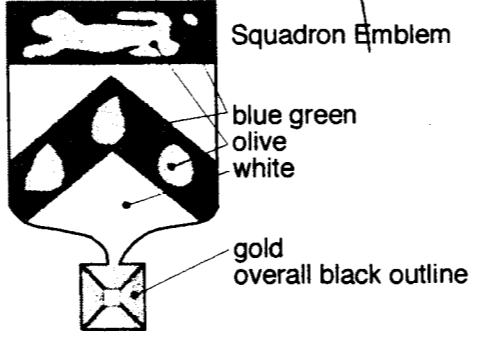
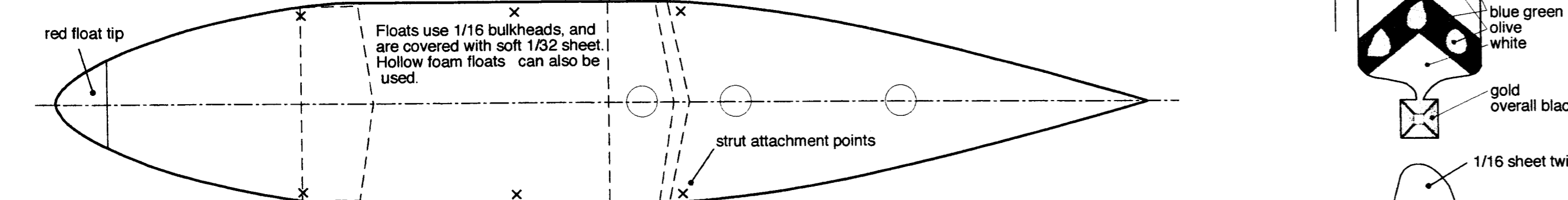
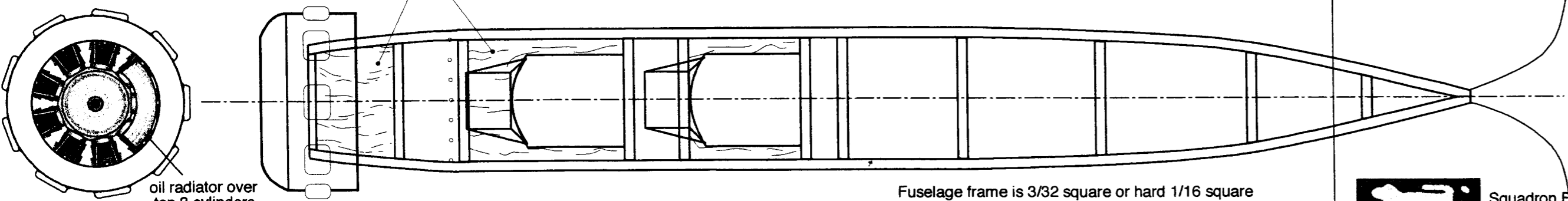

SPECS
 18.3" span
 56 sq. inches wing area
 13.5" overall length

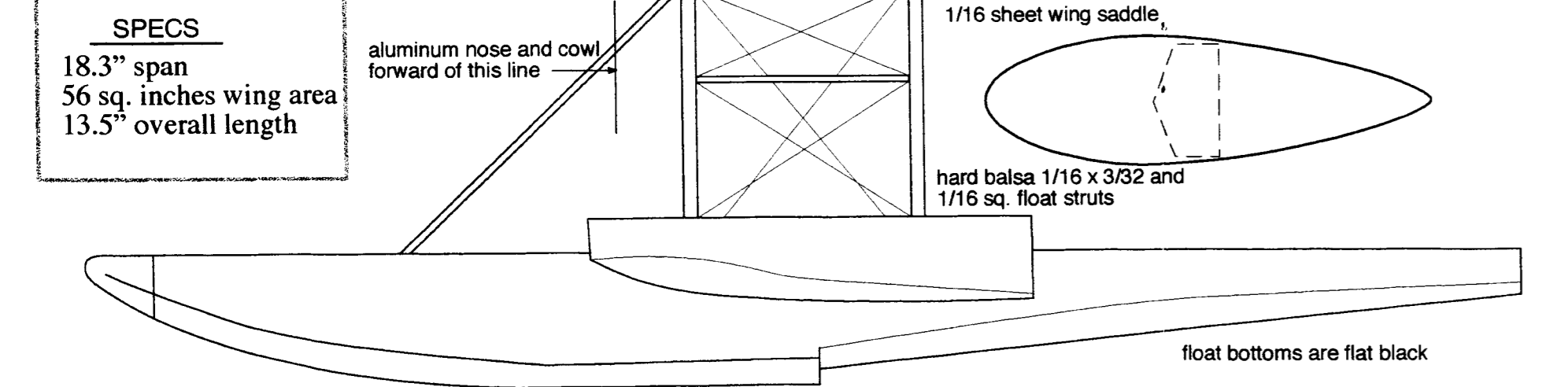

FOR ELECTRIC FREE-FLIGHT

BESSON MB.411
 French Navy Seaplane

Inspired by a Peanut design from **Roger Aime**
 Don Srull 2/99

